



**JMC ROKKER 1000XXR 4-Ch
Amp Kit for 1998-2013
Harley Ultra/Ltd/TriGlide**

#JAMP-1000HC06-UL

**Installation
and Operation
Instructions**

Product Description

This new JMC ROKKER® 1000XXR fairing/rear speaker amplifier kit has been designed specifically for use on the 1998-2013 Harley Ultra, Ultra Ltd or TriGlide with the stock Harley radio. (NOT for CVO Ultra)

This new kit will also connect to the Boss, Jensen, Aquatics, Fosgate or Sony radios, with direct RCA-RCA connections and is easily adjustable in the field with a small screwdriver.

Kit includes custom made connection harnesses and is 100% plug-n-play into the electrical system, providing 4-channels of amplification at 230w RMS power per-channel x4 (920w RMS total) into a 2-ohm speaker load.

New high-efficiency Class-D IC circuitry, (no cooling fans needed) properly shielded against FM/AM radio interference.

PCB is conformal coated for complete protection against water damage in the motorcycle or power sports riding environment.

This ROKKER amplifier uses advanced digital switching power supply technology to dramatically reduce the 12v current demands on the motorcycle electrical system, compared to other brand amplifiers in this power range.

Kit includes top quality heavy gauge power/ground wires for the fused battery connection, along with all necessary mounting hardware & complete installation/operation instructions.

Amplifier is dialed-in for this specific speaker configuration, to provide maximum highway performance.

Amplifier itself measures 8 ¼ x 5 ¾ x 1 ¾".

Installation Instructions

1. Remove the windshield, outer fairing shell, fuel tank and seat.
2. By following the factory wiring harness, route the amplifier power harness from the fairing, under the fuel tank, and on to the battery. (removal of the fuel tank is highly recommended)
3. After first disconnecting the negative battery cable from the battery, connect the positive (red) lead from the amplifier power harness directly to the positive post of the battery. Then connect the negative (black) lead from the power harness to the same bolt/stud on the frame that the negative battery cable is connected to. Then reconnect the negative battery cable to the battery. **(Figure A)** Do not connect the negative (black) lead from the amplifier to the negative post of the battery.
4. By following the factory wiring harness, route the rear speaker harness from the fairing, under the fuel tank, past the battery along each side of the frame and then follow the speaker wires going into the rear speaker pods. The green and green/brown wires go to the right side speaker pod and the brown and white/brown to the left side speaker pod. **(Figure A)**

Fig. B

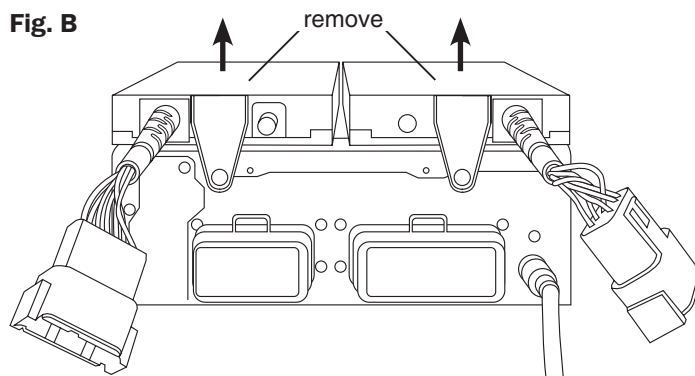
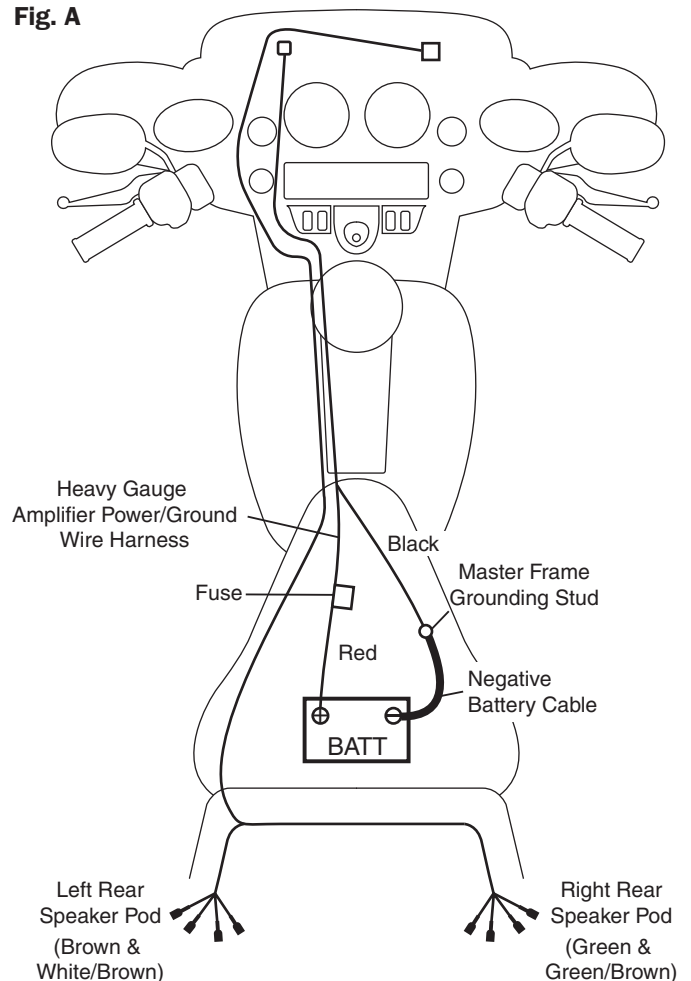
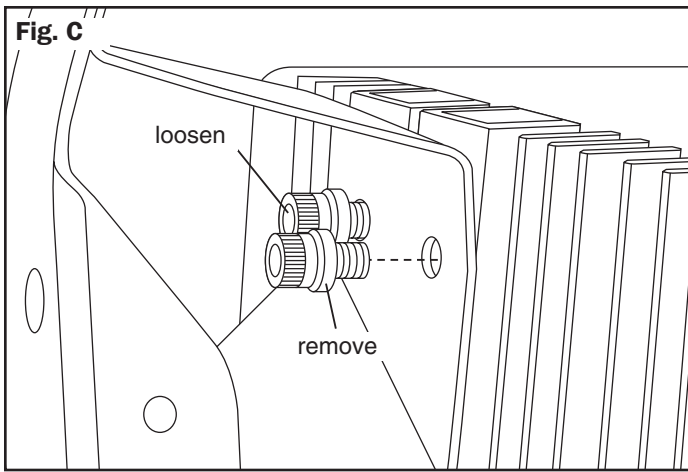

Fig. A



5. Disconnect and remove the CB and/or SAT radio modules from the top of the factory radio. **(Figure B)** Replace the factory retention screws back into the radio.



6. Remove both the left and right forward radio mounting bolts. Loosen but do not remove both the left and right rearward mounting bolts. **(Figure C)**

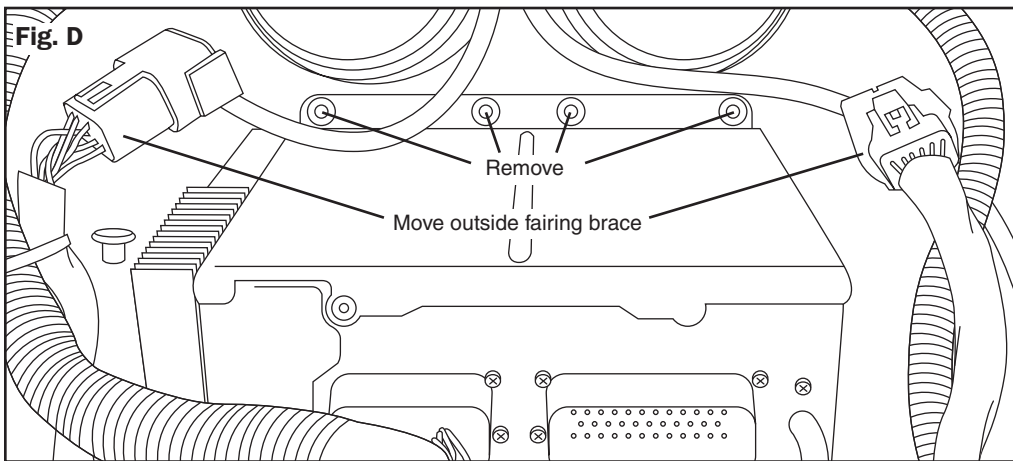

7. Relocate the large plugs from the inside of the fairing braces to the outside of the the fairing braces. **(Figure D)**

8. Remove the (4) rubber grommets from the top of the factory radio. **(Figure D)**

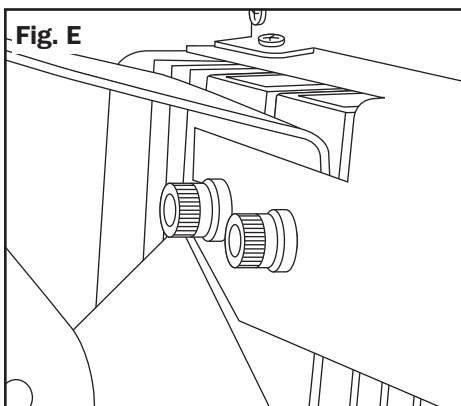

9. Position the J&M Amp/Bracket assembly above the radio and slide into position. (Remove tie-straps and re-position the factory wiring harness as needed to allow the amplifier to fit into place properly) **(Figure E)**

10. Replace the forward radio mounting bolts and then tighten all (4) of the mounting bolts. **(Figure E)**

11. Make Amplifier/Speaker connections according to diagram. **(Figure F)**

Fig. F

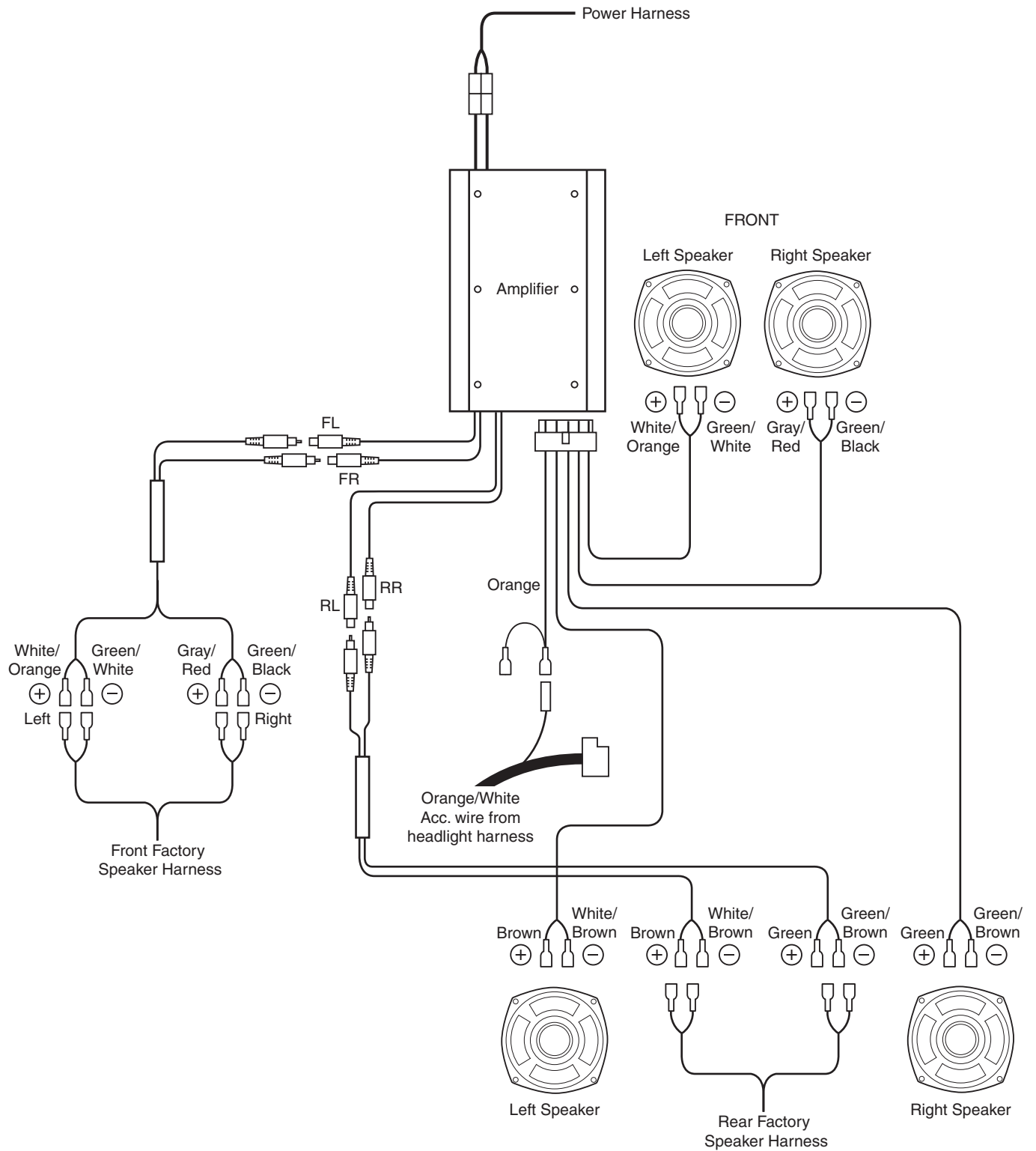

12. Install the previously removed CB and/or SAT Radio module into the J&M lower mounting bracket and secure using the (2) 8-32x1/4 screws provided. (these are the longer of the remaining screws) **(Figure H)**

13. Position the lower bracket assembly below the factory radio and secure using the (4) remaining 8-32x3/16 screws provided. (Figure J) (Remove and re-secure any factory wiring attached to the bottom of the radio using the tie-straps provided. Avoid piling excess wire bundles on top of amplifier.)

14. Re-connect the CB and/or SAT Radio harness and antenna connectors.

15. Test the system for proper operation before reassembling the fairing, realizing that full sound quality and fidelity will not be heard until the outer fairing shell is completely reinstalled.

Fig. G

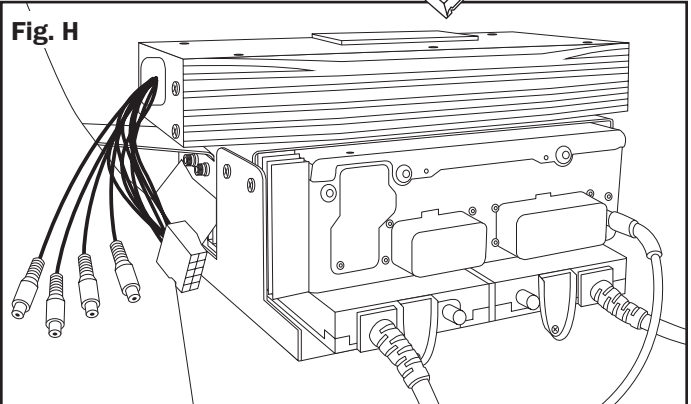
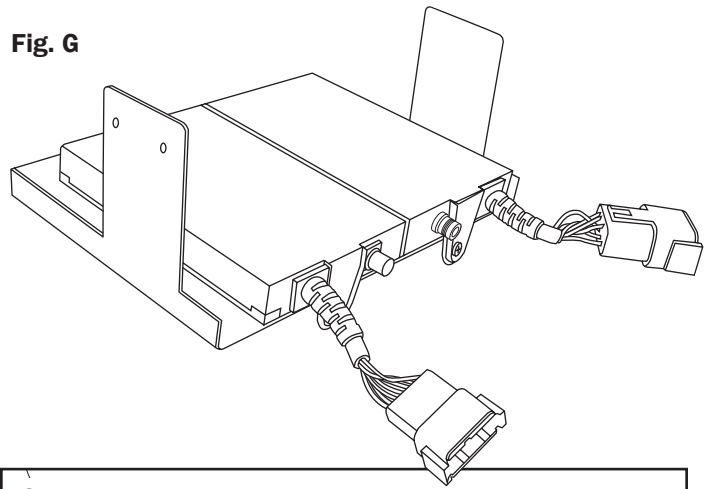

Specifications

ROKKER® 1000XXR

Full Range Class D Amplifier

Output Power (RMS) @ 2% THD 1000Hz 14.4V
Stereo @ 4ohms 4 x 180 Watts – 720w RMS Total
Stereo @ 2ohms 4 x 230 Watts – 920w RMS Total
Frequency Response -3dB 20Hz - 39kHz Capable

S/N Ratio
Separation >90dB
>74dB
Input Sensitivity .35V - 3.9V
Input Impedance 47.5K

Important Programing Note: The amplifier gain & frequency response adjustments have been pre-programed at our factory for this specific Harley Davidson audio system application, using speakers with an impedance of 2-ohms, to provide maximum performance at highway speeds.

Thank you for the confidence you have shown in J&M Corporation by purchasing one of our innovative products.

If you have any question or comments about this product, you may contact us at USA 1-520-624-7000 Monday thru Friday, 8:00AM thru 4:30PM Mountain Standard Time.



1747 E 23rd St
Tucson, AZ 85713 U.S.A.
Tel (520) 624-7000
Website: <http://www.jmcorp.com>
E-mail: audio@jmcorp.com

WARRANTY AND REPAIR INFORMATION

TWO YEAR LIMITED WARRANTY In order to facilitate the servicing of this warranty, the Warranty Registration Form should be filled out and returned within 10 days of the date of purchase. However, return of the Warranty Registration Form is not a precondition of this warranty, and this Warranty will be observed by **J&M CORPORATION** whether or not the Warranty Registration Form is returned, on the condition that other satisfactory evidence of the date of the original purchase is provided to **J&M CORPORATION**.

WHO PROVIDES THE WARRANTY? This warranty is provided by **J&M CORPORATION**.

WHO IS PROTECTED? This warranty is extended only to the original owner of this J&M CORPORATION product and may not be transferred or assigned.

WHAT IS COVERED AND HOW LONG? This warranty covers all defects in material or workmanship of our product for a period of 2 years from date of original retail purchase. At its option, **J&M CORPORATION** will repair or replace any defective part(s) or equipment.

The provisions of the warranty shall not apply to any unit which has been subjected to misuse, neglect, incorrect mechanical or electrical installation, unauthorized modifications, accident, nor to units which have been repaired or altered outside of our factory.

PROCEDURE FOR OBTAINING PERFORMANCE OF WARRANTY In the event that the product does not conform to this warranty, the product should be shipped prepaid to the **J&M CORPORATION** service facility. Transportation charges, insurance fees, and labor costs for shipment, removal, or reinstallation of our product are not covered by this warranty. Loss or damage in shipment is the sole responsibility of the freight carrier.

FOR YOUR INFORMATION Repair as provided under this warranty is the exclusive remedy of the consumer. **J&M CORPORATION** shall not be liable for any incidental or consequential damages or for breach of any express or implied warranty on this product. Except to the extent prohibited by applicable law, any implied warranty of merchantability or fitness for a particular purpose on this product is limited in duration to the duration of the warranty. Some states do not allow the exclusion or limitation of incidental or consequential damages, or allow limitations on how long an implied warranty lasts, so the above limitations or exclusion may not apply to you. This warranty gives you specific legal rights which vary from state to state.

J&M CORPORATION reserves the right to make changes in design and to make improvements in its products without the obligation to incorporate the changes or improvements in any of its previously manufactured products.

J&M CORPORATION has not authorized anyone to make representations or warranties other than the warranty contained herein.

The above warranty is effective for all products manufactured after 10/01/86.

NON-WARRANTY REPAIR RATES **J&M CORPORATION** reserves the right to change the labor repair rates without prior notice. At the time of this printing the out-of-warranty repair is \$40 per hour for labor only. However, the customer is advised to verify the current rate when he/she calls customer service to obtain the return authorization number.

FACTORY SERVICE ADDRESS J&M Corporation, 1747 E 23RD ST, Tucson, Arizona, 85713, U.S.A. Tel: 1-520-624-7000 audio@jmc corp.com www.jmc corp.com

CUSTOMER SERVICE NUMBER 1-520-624-7000

Thank you for the confidence you have shown in J&M Corporation by purchasing one of our innovative products.

If you have any question or comments about this product, you may contact us at USA 1-520-624-7000 Monday thru Friday, 8:00AM thru 5:00PM Mountain Standard Time.



1747 E 23RD ST Tucson, AZ
85713 U.S.A.
Tel 1-520-624-7000
Website: <http://www.jmc corp.com>
E-mail: audio@jmc corp.com



WARRANTY REGISTRATION FORM Please fill out this card completely and mail it immediately after purchase. Please be sure that your zip code and serial number (if applicable) are legible. This will help us to serve you better.

(PLEASE PRINT)

Name _____

Address _____

City _____ State _____ Zip _____

Motorcycle Other E-mail _____

Make _____ Model _____ Year _____

Product part number _____

Serial number (if applicable) _____

Date of purchase _____

Name of dealer it was purchased from _____



Mail to:
JM Corporation 1747 E
23RD ST Tucson, AZ
85713
U.S.A.